

# PREFADUR, S.L.

Pol. Peña Blanca, Parcela 1. 18657. Nigüelas (Granada)  
Tel. 958 780 640; Fax 958 780 640

## ARQUETA

60 x 60 x 70 sin fondo

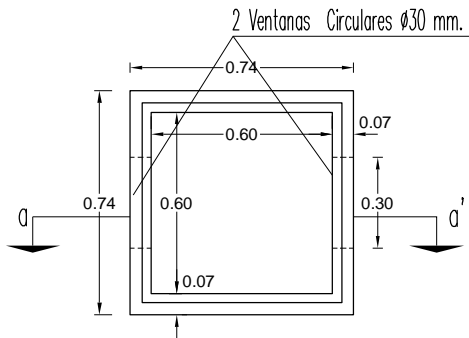

PLANTA

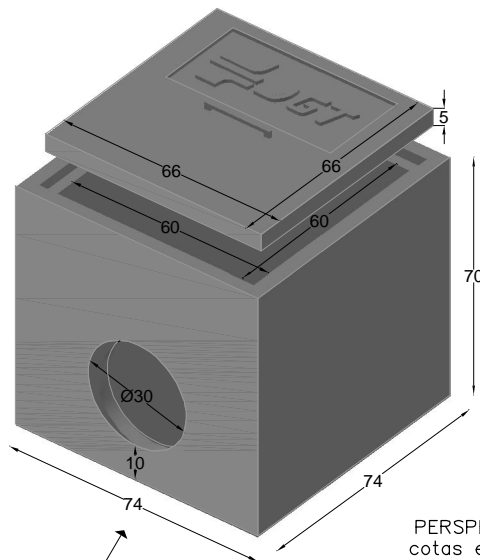

PERSPECTIVA  
cotas en cm.

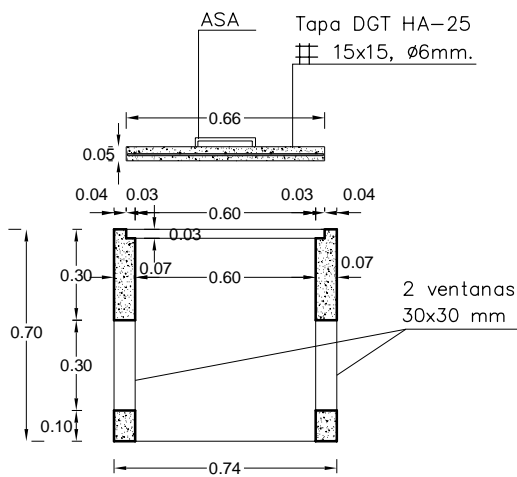

SECCION a-a'

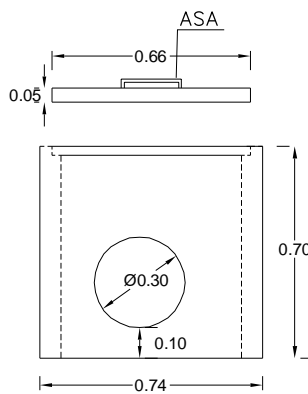

VISTA A

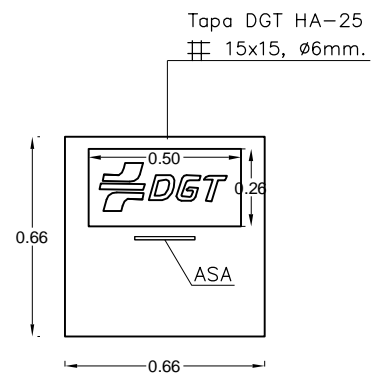

TAPA

ESCALA 1/25 cotas en m.

### CARACTERISTICAS TÉCNICAS:

ARQUETA SIN FONDO	60 x 60 x 70
TIPO DE HORMIGÓN EN ARQUETA	HM- 300
TIPO DE HORMIGÓN EN TAPA	HA- 300
TIPO DE CEMENTO	CEM-I- 52,5 R
PESO ARQUETA (kg/ Unidad)	328 Kg.
PESO TAPA (kg/ Unidad)	54.5 Kg.
ARMADURA TAPA	⌘ 15x15, Ø6mm.