

PREFADUR, S.L.

Pol. Peña Blanca, Parcela 1. 18657. Nigüelas (Granada)
Tel. 958 780 640; Fax 958 780 640

ARQUETA A2 a 1.50 ENDESA 116 X 64 X 150

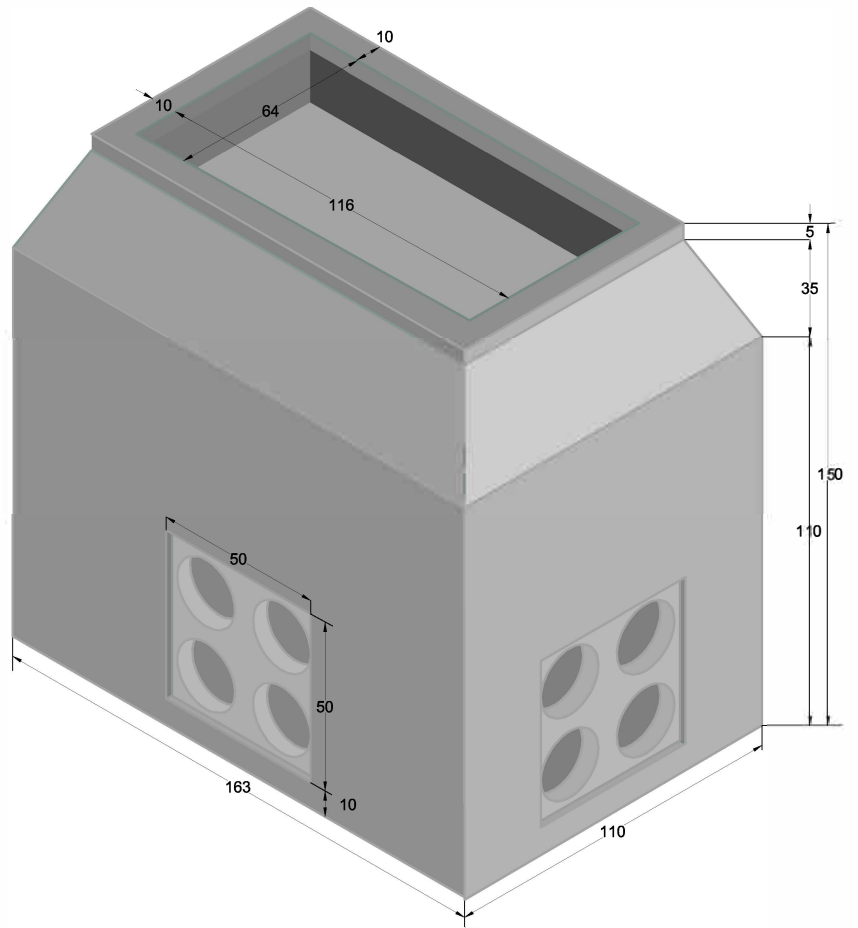
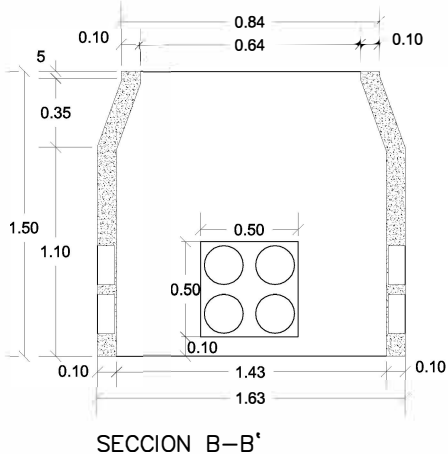
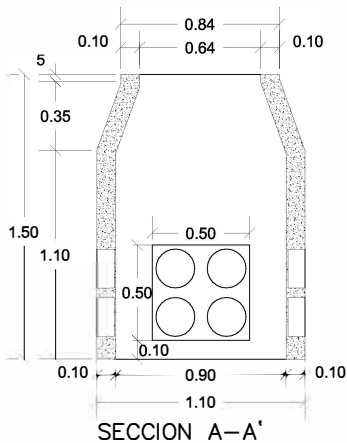
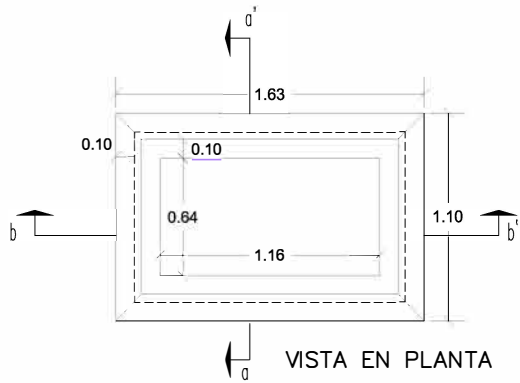

cotas en cm.

ESCALA 1/40 cotas en m.

CARACTERISTICAS TÉCNICAS:

ARQUETA A2 a 1.50	116 x 64 x 150
TIPO DE HORMIGÓN	HM-300
TIPO DE CEMENTO	CEM-I-52,5 SR
PESO (kg/ Unidad)	1600 Kg.