

PREFADUR, S.L.

Pol. Peña Blanca, Parcela 1. 18657. Nigüelas (Granada)
Tel. 958 780 640; Fax 958 780 640

BAJANTE 100 X 60 X 20 H/MASA

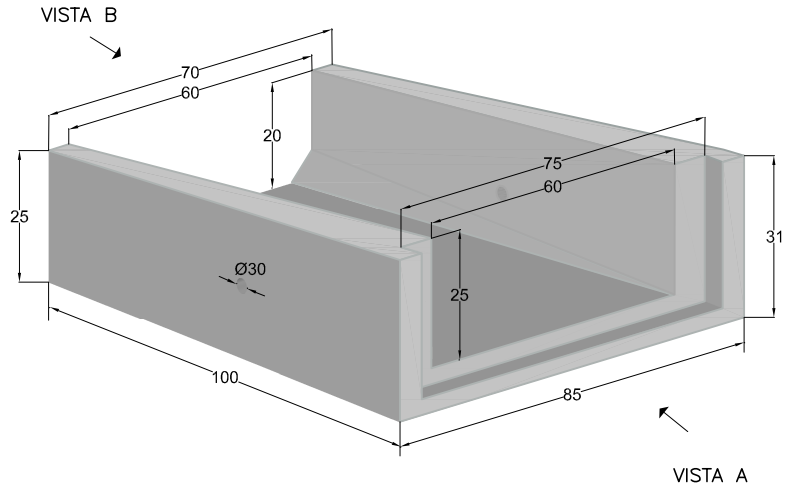
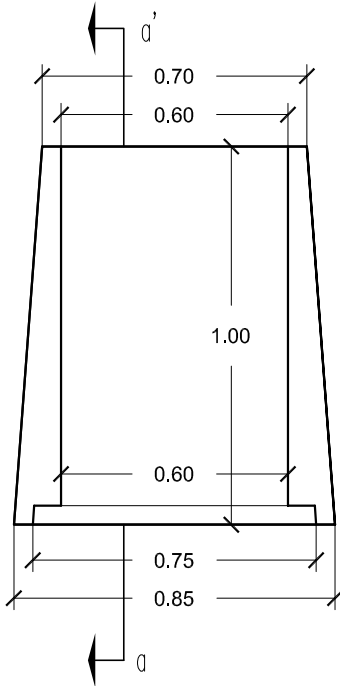

PERSPECTIVA
cotas en cm.

VISTA EN PLANTA

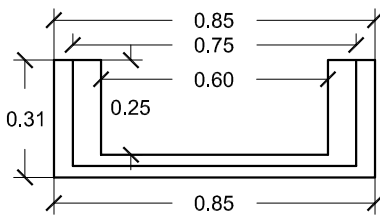

VISTA A

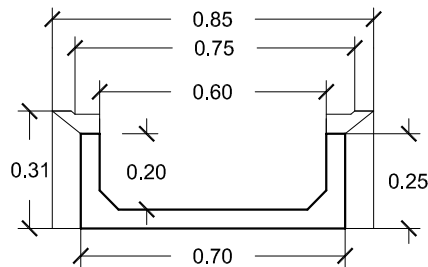

VISTA B

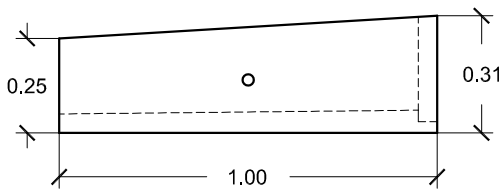

PERFIL

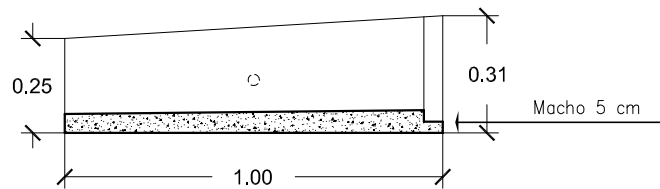

SECCIÓN a-a'

ESCALA 1/20 cotas en m.

CARACTERÍSTICAS TÉCNICAS:

BAJANTE	100 x 60 x 20
MATERIAL	HM-250
TIPO DE CEMENTO	CEM-I-42,5 R FYM
PESO (kg/ Unidad)	230 Kg.
RESISTENCIA MINIMA DEL HORMIGON	25,00 N/mm ² .